



Premise
Installation
Guide





Table of Contents

| | |
|--|-------|
| Overview of Cabling Standards | 1-2 |
| Horizontal Cabling System Structure | 3-5 |
| Work Area | 6 |
| Horizontal Distances of Copper Links (Open Office) | 7 |
| Twisted Pair (Balanced) Cabling | 8 |
| Horizontal UTP Cable | 8 |
| UTP Patch Cords & Cross-Connect Jumpers | 9 |
| TIA/EIA-568-B.1 | 10-11 |
| TIA/EIA-568-B.2 | 12 |
| TIA/EIA-568-B.3 | 12-13 |
| Straight-Through or Reversed | 14 |
| How to Read a Modular Cord | 14 |
| Common Outlet Configurations | 14-15 |
| Wire Color Codes | 16 |
| Application-Specific Pair Assignments | 17 |
| Recommended Cabling Practices | 18-19 |
| UTP Connector Terminations | 19 |
| NEC Fire Resistance Levels | 20 |
| NEC Substitution Chart | 21 |
| Notes | 23-24 |

This easy to follow reference guide is designed to assist you in installing, terminating and testing category unshielded twisted pair (UTP) cables to maximize their performance, and ensure they meet or exceed ANSI/TIA/EIA-568-B standards.



Overview of Cabling Standards

ANSI/TIA/EIA-568-B

ANSI/TIA/EIA-568-B ('568-B) replaced ANSI/TIA/EIA-568-A as the “Commercial Building Telecommunications Cabling Standard” in May 2001. All addenda of 568-A and all TSBs (67, 72, 75 and 95) have been incorporated into the new standard.

The 568-B document is broken into three sections:

B.1 - General Requirements

B.2 - Balanced Twisted Pair Cabling Components

B.3 - Optical Fiber Cabling Components Standards

For clarity and consistency, '568-B based terminology is used in the following overview.

Purpose

- To specify a generic voice and data telecommunications cabling system that will support a multi-product, multi-vendor environment.
- To provide direction for the design of telecommunications equipment and cabling products intended to serve commercial enterprises.
- To enable the planning and installation of a structured cabling system for commercial buildings that is capable of supporting the diverse telecommunications needs of building occupants.
- To establish performance and technical criteria for various types of cable and connecting hardware, and cabling system design and installation.



Overview of Cabling Standards

Scope

- Specifications are intended for telecommunications installations that are “office oriented.”
- Requirements are for a structured cabling system with a usable life in excess of 10 years.
- Specifications addressed:
 - Recognized Media
 - Cable and Connecting Hardware
 - Performance
 - Topology
 - Cabling Distance
 - Installation Practices
 - User Interfaces
 - Channel Performance

Cabling Elements

- Horizontal Cabling:
 - Horizontal Cross-Connect (HC)
 - Horizontal Cable
 - Consolidation Point (CP) (optional)
 - Transition Point (TP) (optional)
 - Telecommunications Outlet/Connector (TO)
- Backbone Cabling:
 - Main Cross-Connect (MC)
 - Interbuilding Backbone Cable
 - Intermediate Cross-Connect (IC)
 - Intrabuilding Backbone Cable
- Work Area (WA)
- Telecommunications Room (TR)
- Equipment Room (ER)
- Entrance Facility (EF)
- Administration

Horizontal Cabling System Structure

The horizontal cabling system extends from the telecommunications outlet in the work area to the horizontal cross-connect in the telecommunications room. It includes the telecommunications outlet, an optional consolidation point or transition point connector, horizontal cable, and the mechanical terminations and patch cords (or jumpers) that are parts of the horizontal cross-connect.

TELECOMMUNICATIONS ROOM (TR)

- A = Customer Premises Equipment**
- B = HC Equipment Cord**
- C = Patch Panel**
- D = Patch cords/cross-connect jumpers used in the HC, including equipment cables/cords, should not exceed 6m (20 ft.)**
- E = Horizontal Cable 90m (295 ft.) max. total**
- F = CP or TP (optional)**
- G = Telecommunications Outlet/Connector (TO)**
- H = WA Equipment Cord**
- I = WA PC**

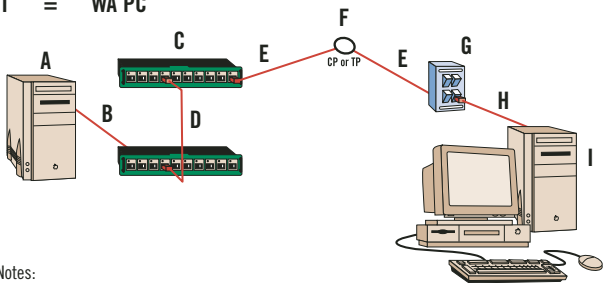

Notes:

- An allowance of 10m (33 ft.) has been provided for the combined length of patch cords/cross-connect jumpers and equipment cables/cords in the HC, including the WA equipment cords.
- An allowance is made for WA equipment cords of 3m (9.8 ft.).



Horizontal Cabling System Structure

WORK AREA (WA)

Some points specified for the horizontal cabling subsystem include:

- Recognized Horizontal Cables:
 - 4-pair 100 Ω unshielded twisted pair (UTP) or screened twisted pair (ScTP)
 - 2-fiber (duplex) 62.5/125 μm or 50/125 μm
- Multi-pair and multi-unit cables are allowed, provided that they satisfy the hybrid and bundled cable requirements of TIA/EIA-568-B.2.
- Grounding must conform to applicable building codes, as well as ANSI/TIA/EIA-607.
- A minimum of two telecommunications outlets are required for each individual work area per TIA/EIA-568-B.1.
 - First outlet:** 100 Ω Category 3 twisted pair (Category 5e is recommended).
 - Second outlet:** 100 Ω Category 5e twisted pair (Category 6 is recommended) or two-fiber multi-mode optical fiber either 62.5/125 μm or 50/125 μm .
- One transition point (TP) is allowed between different forms of the same cable type (i.e., where undercarpet cable connects to round cable).
- 50 Ω coax and 150 Ω STP-A cabling are not recommended for new installations.
- Additional outlets may be provided. These outlets are in addition to and may not replace the minimum requirements of the standard.
- Bridged taps and splices are not allowed for copper-based horizontal cabling (splices are allowed for fiber).
- Application-specific components shall not be installed as part of the horizontal cabling. When needed, they must be placed external to the telecommunications outlet or horizontal cross-connect (e.g., splitters, baluns).
- The proximity of horizontal cabling to sources of electromagnetic interference (EMI) shall be taken into account.

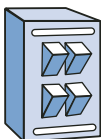
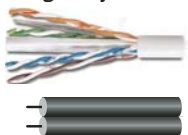

Horizontal Cabling System Structure

Star Topology

Horizontal cabling shall be configured in a star topology, with each work area outlet connected to a horizontal cross-connect (HC) in a telecommunications room (TR).

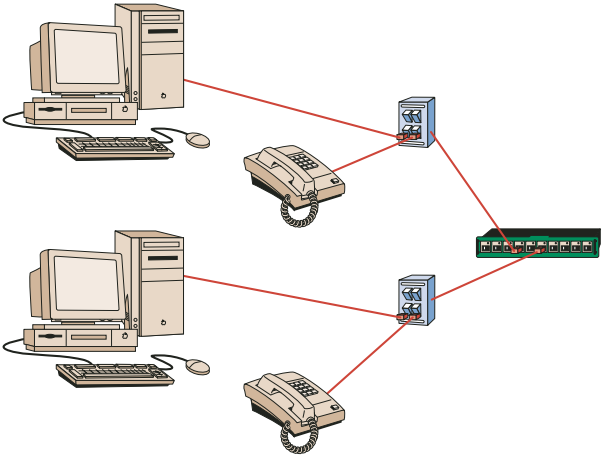

Home Run Cabling

A distribution method in which individual cables are run directly from the network interface device to each communications outlet in different rooms.

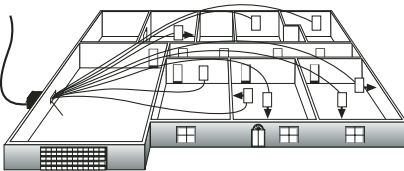



Work Area

The telecommunications outlet serves as the work area interface to the cabling system.

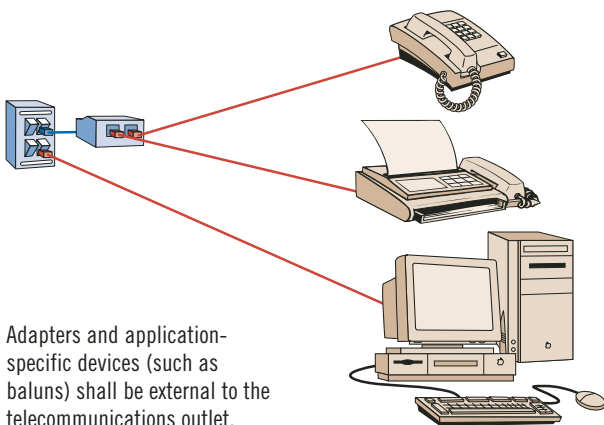

Some specifications related to work area cabling:

- Equipment cords are assumed to have the same performance as patch cords of the same type and category.
- When used, adapters are assumed to be compatible with the transmission capabilities of the equipment to which they connect.
- Horizontal cable lengths are specified with the assumption that a maximum cable length of 3m (10 ft.) is used for equipment cords in the work area.

Note: For establishing maximum horizontal channel distances, a combined maximum length of 10m (33 ft.) is allowed for patch cables (or jumpers) and equipment cables in the work area and the telecommunications room.



Horizontal Distances of Copper Links (Open Office)

Copper work area cables connected to a MuTOA (Multi-user Telecommunications Outlet Assembly) shall meet the requirements of '568-B.1. The maximum length of copper work area cables shall be determined according to:

$$C=(102-H)/1.2$$

$$W=C-5(<20m)$$

Where:

C is the combined length of the work area cable, equipment cable and patch cord (m).

W is the length of the work area cable (m).

H is the length of the horizontal cable (m).

The above equations assume that there is a total of 5m (16 ft.) of patch and equipment cables in the telecommunications room. Table 1 shows the application of these formulas. The length of work area cables shall not exceed 20m (66 ft.). The MuTOA shall be marked with the maximum allowable work area cable length.

Table 1 - Maximum Length of Work Area Cables

| Length of Horizontal Cable | Maximum Length of Work Area Cable | Maximum Combined Length of Work Area Cables, Patch Cords and Equipment Cable |
|----------------------------|-----------------------------------|--|
| H m (ft.) | W m (ft.) | C m (ft.) |
| 90 (295) | 5 (16) | 10 (33) |
| 85 (279) | 9 (30) | 14 (46) |
| 80 (262) | 13 (44) | 18 (59) |
| 75 (246) | 17 (57) | 22 (72) |
| 70 (230) | 22 (71) | 27 (89) |



Twisted Pair (Balanced) Cabling

The three categories of transmission performance specified by TIA-568-B.2 for cables, connecting hardware, link and channel are:

Category 3

Transmission characteristics are specified up to 16 MHz

Typical Applications

10BASE-T, 4 Mbps Token Ring, 52 Mbps ATM, 100VG-ANYLAN

Category 5e

Transmission characteristics are specified up to 100 MHz

Typical Applications

1000BASE-T (Gigabit Ethernet), 100BASE-TX, 16 Mbps Token Ring, 155 Mbps ATM

Category 6

Transmission characteristics up to 250 MHz

Typical Applications

Gigabit Ethernet and beyond

Horizontal UTP Cable

- Solid 4-pair 24AWG (0.51mm) specified, 22AWG (0.64mm) solid also allowed. An overall shield (ScTP) is optional.
- Performance marking should be provided to show the applicable performance category. These markings do not replace safety markings.
- Color Coding:
 - white/blue - blue
 - white/orange - orange
 - white/green - green
 - white/brown - brown



UTP Patch Cords & Cross-Connect Jumpers

- Patch cords should use stranded conductors for adequate flex life.
- Patch cords must meet the minimum performance requirements for horizontal cable except that 20 percent more attenuation is allowed by '568-B.2.
- Performance markings should be provided to show the applicable transmission category in addition to safety markings.
- Insulated O.D. of stranded wires should be 0.8mm (0.032 in.) to 1mm (0.039 in.) to fit into a modular plug.
- Color Codes for Stranded, 100 Ω UTP Patch Cord:
 - white/blue - blue PAIR 1
 - white/orange - orange PAIR 2
 - white/green - green PAIR 3
 - white/brown - brown PAIR 4
- Color code for cross-connect jumpers: One conductor white, the other a visibly distinct color such as red or blue.



Note: Because of their identical pair groupings, patch cords terminated with either T568A or T568B pair assignments may be used interchangeably, provided that both ends are terminated with the same pin/pair scheme.

Nominal Velocity of Propagation (NVP) for General Cable Products

| Category | CMR NVP | CMP NVP |
|-------------|------------|------------|
| Category 3 | 64 | 65 |
| Category 5e | 70 | 72 |
| Category 6 | 70 | 72 |



TIA/EIA-568-B.1

Channel Test Configuration

The channel test configuration is to be used by system designers and users of data communications systems to verify the performance of the overall channel. The channel includes up to 90m (295 ft.) of horizontal cable, a work area equipment cord, telecommunications outlet/connector, an optional transition/consolidation connector and two connections in the telecommunications room. The total length of equipment cords, patch cords or jumpers, and work area cords shall not exceed 10m (33 ft.). The connections to the equipment at each end of the channel are not included in the channel definition.

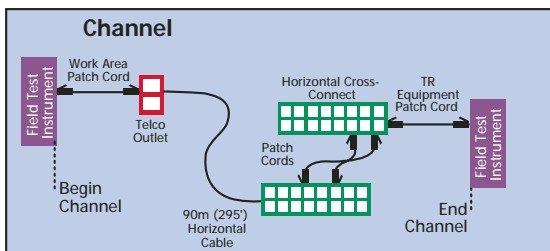

| Channel | TIA/EIA-568-B Category 3 (@ 16 MHz) | TIA/EIA-568-B Category 5e (@ 100 MHz) | TIA/EIA-568-B Category 6 (@ 100/250 MHz) |
|------------------|---|---|--|
| Attenuation (dB) | 14.9 | 24.0 | 21.3/35.9 |
| NEXT (dB) | 19.3 | 30.1 | 39.9/33.1 |
| ELFEXT (dB) | N/A | 17.4 | 23.3/15.3 |
| Return Loss (dB) | N/A | 10.0 | 12.0/8.0 |
| ACR (dB) | 4.4 | 6.1 | 18.6/N/A |

Permanent Link Test Configuration

The permanent link test configuration is to be used by installers and users of data telecommunications systems to verify the performance of permanently installed cabling. The permanent link consists of up to 90m (295 ft.) of horizontal cabling and one connection at each end, and may also include an optional transition/consolidation point connection. The permanent link excludes both the cable portion of the field test instrument cord and the connection to the field test instrument.

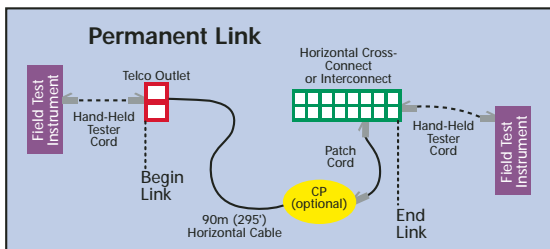

| Permanent Link | TIA/EIA-568-B Category 3 (@ 16 MHz) | TIA/EIA-568-B Category 5e (@ 100 MHz) | TIA/EIA-568-B Category 6 (@ 100/250 MHz) |
|------------------|-------------------------------------|---------------------------------------|--|
| Attenuation (dB) | 13.0 | 21.0 | 18.6/31.1 |
| NEXT (dB) | 21.0 | 32.3 | 41.8/35.3 |
| ELFEXT (dB) | N/A | 18.6 | 24.2/16.2 |
| Return Loss (dB) | N/A | 12.0 | 14.0/10.0 |
| ACR (dB) | 8.0 | 11.3 | 23.2/4.2 |



TIA/EIA-568-B.2

The transmission performance of a cabling system depends upon the characteristics of the horizontal cable, connecting hardware, patch cords, equipment cords, work area cords, cross-connect wiring, the total number of connections, and the care with which they are installed and maintained. The development of high-speed applications requires that cabling systems be characterized by transmission parameters such as insertion loss, PSNEXT loss, return loss, and PSELFEXT. System designers use these performance criteria to develop applications that utilize all four pairs in a cabling system for simultaneous bi-directional transmission. This standard provides minimum cabling component performance criteria as well as procedures for component and cabling performance validation. This standard also specifies field test instruments and applicable reference measurement procedures for all transmission parameters.

This standard specifies minimum requirements for balanced twisted-pair telecommunications cabling components that are used up to and including the telecommunications outlet/connector and between buildings in a campus environment. This standard specifies the minimum performance requirements for recognized balanced twisted-pair cabling components as described in ANSI/TIA/EIA-568-B.1 (i.e. cable, connectors, connecting hardware, patch cords, equipment cords, work area cords and jumpers) and for the field test equipment used to verify the performance of these components as installed.

TIA/EIA-568-B.3

Optical Fiber Cabling Components

This standard contains the performance specifications for the optical fiber cables recognized in premises cabling standards. Cable transmission performance for the outside plant telecommunications cable shall comply with ANSI/ICEA S-87-640. Inside plant optical fiber telecommunications cable shall comply with ANSI/ICEA S-83-596. Each cabled fiber shall meet the graded performance specifications of the table to the right.

The optical fiber cable construction shall consist of 50/125mm or 62.5/125mm Multi Mode optical fibers or Single Mode optical fibers, or a combination of these media. Individual fibers or groups of fibers



TIA/EIA-568-B.3

shall be identifiable in accordance with ANSI/TIA/EIA-598-A. The cable shall be listed and marked as required under the applicable electrical code and local building code requirements.

Bend Radius:

Inside plant: 2- and 4-fiber cables intended for horizontal or centralized cabling shall support a bend radius of 1 inch under no-load conditions. 2- and 4-fiber cables intended to be pulled through horizontal pathways during installation shall support a bend radius of 2 inches under a pull load of 222N (50 lbf). All other inside plant cables shall support a bend radius of 10 times the cable's outside diameter when not subject to tensile load, and 15 times the cable's outside diameter when subject to tensile loading up to the cable's rated limit.

Outside plant: Optical fiber cables shall be of a water-block construction and meet the requirements for compound flow and water penetration. Outdoor cable shall have a minimum pull strength of 2670N (600 lbf). Outside plant cables shall support a bend radius of 10 times the cable's outside diameter when not subject to tensile load, and 20 times the cable's outside diameter when subject to tensile loading up to the cable's rated limit.

Optical Fiber Cable Transmission Performance Parameters

| Optical Fiber Cable Type | Wavelength (nm) | Max. Attenuation (dB/km) | Min. information transmission capacity for over filled launch (MHz/km) |
|-----------------------------|-----------------|--------------------------|--|
| 50/125 μ m Multi Mode | 850 | 3.5 | 500 |
| | 1300 | 1.5 | 500 |
| 62.5/125 μ m Multi Mode | 850 | 3.5 | 160 |
| | 1300 | 1.5 | 500 |
| Single Mode Inside Plant | 1310 | 1 | N/A |
| | 1550 | 1 | N/A |
| Single Mode Outside Plant | 1310 | 0.5 | N/A |
| | 1550 | 0.5 | N/A |



Straight-Through or Reversed

Modular cords are used for two basic applications. One application uses them for patching between modular patch panels. When used in this manner, modular cords should always be wired “straight-through” (pin 1 to pin 1, pin 2 to pin 2, pin 3 to pin 3, etc.). The second major application uses modular cords to connect the workstation equipment (PC, phone, FAX, etc.) to the modular outlet. These modular cords may either be wired “straight-through” or “reversed” (pin 1 to pin 6, pin 2 to pin 5, pin 3 to pin 4, etc.), depending on the system manufacturer’s specifications. This “reversed” wiring is typically used for voice systems. The following is a guide to determine what type of modular cord you have.

How to Read a Modular Cord

Align the plugs side-by-side with the contacts facing you and compare the wire colors from left to right. If the colors appear in the same order on both plugs, the cord is wired “straight-through.” If the colors appear reversed on the second plug (from right to left), the cord is wired “reversed.” To do a cross-over, put 568A on one end and 568B on the other.



Common Outlet Configurations

Two wiring schemes have been adopted by the '568-B and '11801 Standards. They are nearly identical except that pairs two and three are reversed. T568A is the preferred scheme because it is compatible with 1- or 2-pair USOC systems. Either configuration can be used for Integrated Services Digital Network (ISDN) and high speed data applications. Transmission Categories 3, 5e and 6 are only applicable to this type of pair grouping.

Common Outlet Configurations

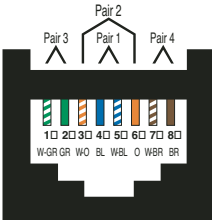

T568A

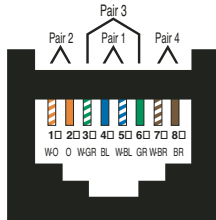

T568B

10BASE-T & 100BASE-T wiring specifies an 8-position jack but uses only 2 pairs. These are pairs 2 and 3 of T568A and T568B schemes. 1000BASE-T will use all 8 pins.

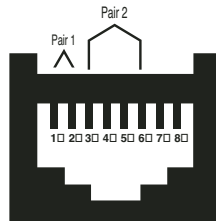

10BASE-T (802.3)

Token Ring wiring uses either an 8-position or 6-position jack. The 8-position format is compatible with T568A, T568B and USOC wiring schemes.

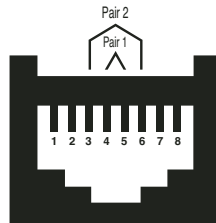

TOKEN RING (802.5)

ANSI X3T9.5 TP-PMD uses the two outer pairs of an 8-position jack. These positions are designated as pair 3 and pair 4 of the T568A wiring scheme. This wiring scheme is also used for ATM.

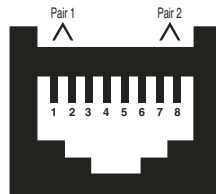

TP-PMD (X3T9.5) & ATM



Wire Color Codes

A. Band-Striped Twisted Pair Wire

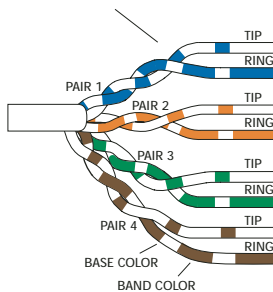

B. Solid-Color Non-Twisted Wire

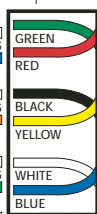

C. Quad Wire*, Solid-Color, Non-Twisted Wire

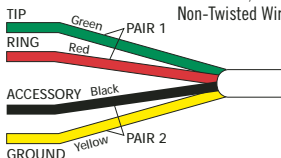

Standard 4-Pair Wiring Color Codes

| | | |
|--------|---|--------------|
| PAIR 1 | T | White/Blue |
| | R | Blue/White |
| PAIR 2 | T | White/Orange |
| | R | Orange/White |
| PAIR 3 | T | White/Green |
| | R | Green/White |
| PAIR 4 | T | White/Brown |
| | R | Brown/White |

Note:

White band-stripe on ring conductor is optional.

For 6-wire jacks use pair 1, 2 and 3 color codes.

For 4-wire jacks use pair 1 and 2 color codes.

*** CAUTION**

Quad wire is no longer acceptable for installation in multi-line environments. If encountered during a retrofit, quad wire should be replaced with 100Ω UTP if possible. Connecting new quad to installed quad will only amplify existing problems and limitations associated with quad wire. Leaving existing quad in place and connecting 100Ω UTP to it may also be ineffective, as the quad wire may negate the desired effect of the UTP.

Application-Specific Pair Assignments

APPLICATION-SPECIFIC PAIR ASSIGNMENTS FOR 100 OHM CABLING

| Application | Pins 1-2 | Pins 3-6 | Pins 4-5 | Pins 7-8 |
|-----------------------|----------|-----------------------|-----------------------|----------|
| ISDN | Power | TX | RX | Power |
| Analogue Voice | — | — | TX/RX | — |
| 802-3 (10BASE-T) | TX | RX | — | — |
| 802-5 (Token Ring) | — | TX | RX | — |
| FDDI (TP-PMD) | TX | Optional ¹ | Optional ¹ | RX |
| ATM User Device | TX | Optional ¹ | Optional ¹ | RX |
| ATM Network Equipment | RX | Optional ¹ | Optional ¹ | TX |
| 1000BASE-T | TX/RX | TX/RX | TX/RX | TX/RX |
| 100BASE-VG (802.12) | Bi | Bi | Bi | Bi |
| 100BASE-T4 (802.3u) | TX | RX | Bi | Bi |
| 100BASE-TX (802.3u) | TX | RX | — | — |

*Bi=Bi-directional TX=Transmit RX=Receive

¹Optional terminations may be required by some manufacturers' active implementations.



Recommended Cabling Practices

Do:

- Do terminate each horizontal cable on a dedicated telecommunications outlet.
- Do locate the main cross-connect near the center of the building to limit cable distances.
- Do maintain the twist of horizontal and backbone cable pairs up to the point of termination.
- Do tie and dress horizontal cables neatly.
- To avoid stretching, pulling tension should not exceed 110N (25 lbf) for 4-pair cables.
- Installed bend radii shall not exceed:
 - 4 times the cable diameter for horizontal UTP cables.
 - 10 times the cable diameter for multi-pair backbone UTP cables.
- Horizontal cables should be used with connecting hardware and patch cords (or jumpers) of the same performance category or higher.
- Avoid cable stress, as caused by:
 - cable twist during pulling or installation
 - tension in suspended cable runs
 - tightly cinched cable ties or staples
 - tight bend radii









Do Not:

- Do not use connecting hardware that is of a lower category than the cable being used.
- Do not create multiple appearances of the same cable at several distribution points (called bridged taps).
- Do not over-tighten cable ties, use staples, or make sharp bends with cables.
- Do not place cable near equipment (i.e., generators, transformers, engines, medical equipment, etc.) that may generate high levels of electromagnetic interference.
- Do not exceed 90° bend.

Important Note: Installed UTP cabling shall be classified by the least performing component in the link.



Recommended Cabling Practices

| | | | |
|--|--|--|--|
| Keep bend radius to greater than four times UTP cable diameter | Minimize the number of 90° bends | Never exceed a 90° bend | Minimize amount of jacket twisting |
|   |   |   |   |
| Apply cable ties loosely & at random intervals | Do not over tighten cable ties and avoid applying with periodic spacing | | Avoid torn jacket due to over twisting cable during installation and avoid torn jackets due to snags |

UTP Connector Terminations

- Pair twists shall be maintained as close as possible to the point of termination.
- Untwisting shall not exceed 75mm (3 inches) for Category 3 links and 13mm (0.5 inch) for Category 5e and Category 6 links.
- Connecting hardware shall be installed to provide well-organized installation with cable management and in accordance with the manufacturer's guidelines.
- Strip back only as much jacket as is required to terminate individual pairs.
- To maintain cable geometry, remove the cable jacket only as much as necessary to terminate the cable pairs on the connecting hardware.



NEC Fire Resistance Levels

Communication wire and cable for premise installations in accordance with Article 800 and other applicable parts of the National Electrical Code (NEC) latest issue. Communication wire and cables for Canada are in accordance with the harmonized Canadian Standard Association C22.2 No. 214, Underwriters Laboratories UL 444 latest issue.

| Fire Resistance Level | Test Requirement | NEC Article | | | |
|---|---|-------------|--------------|------|-------|
| | | 800 | 725 | 760 | 820 |
| (Highest) Plenum Cables | UL-910 (Steiner tunnel) CSA-CMP (Steiner tunnel) | CMP | CL3P CL2P | FPLP | CATVP |
| Riser Cables Multiple Floors | UL-1666 (Vertical Shaft) CSA-CMG (Vertical Tray) | CMR | CL3R CL2R | FPLR | CATVR |
| General Purpose Cables | UL-1581 (Vertical Tray) | CMG | CL3 CL2 | FPL | CATV |
| (Lowest) Residential Cables Restricted Use | CSA-CMG (Vertical Tray) UL-1581 VW-1 | CMX | CL2X CL3X | | CATVX |

- Notes:
1. Cables with a higher fire resistance level may be substituted for those with a lower fire resistance level.
 2. Non-fire rated outside plant telephone cables may not run outside of a rigid metal conduit more than 50 feet from the point of entrance into a building.
 3. Cables rated CMG or CM may be used in runs penetrating one floor (NEC 800-53).

NEC Substitution Chart

Figure 800-53. Cable Substitution Hierarchy

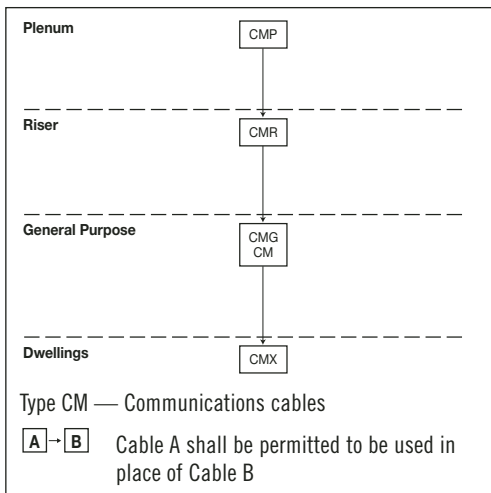

Article 800

Table 800-53. Cable Uses and Permitted Substitutions

| Cable Type | Use | References | Permitted Substitutions |
|------------|--------------------------------------|------------|-------------------------|
| CMP | Communications plenum cable | 800-53 (a) | — |
| CMR | Communications riser cable | 800-53 (b) | CMP |
| CMG, CM | Communications general purpose cable | 800-53 (d) | CMP, CMR |
| CMX | Communications cable, limited use | 800-53 (d) | CMP, CMR, CMG, CM |

Note: See Figure 800-53. Cable Substitution Hierarchy
From 2002 NEC

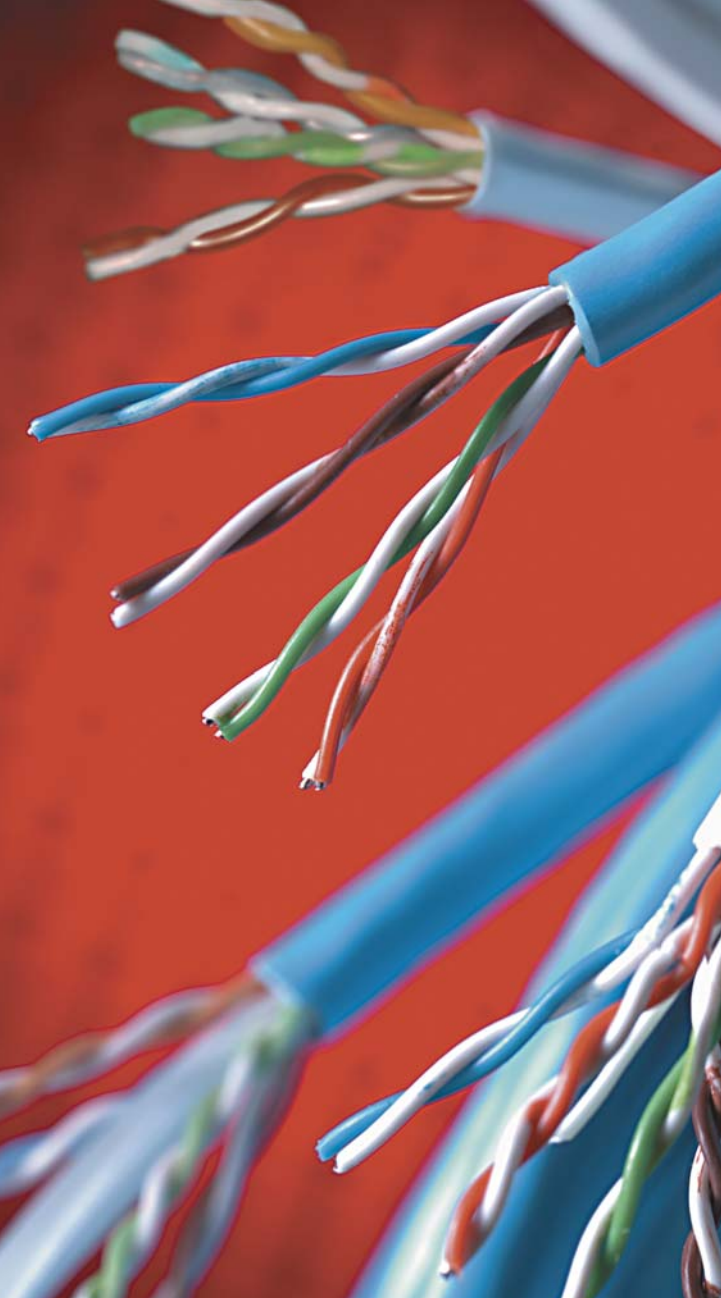



Notes:

All information in this document is presented solely as a guide and is believed to be reliable. All printing errors are subject to correction in subsequent releases of this guide, although General Cable has taken precautions to ensure accuracy.

© 2004. General Cable Technologies Corporation.
Highland Heights, KY 41076
All rights reserved.

No part of this publication may be reproduced or transmitted in any form or by any means, electronic or mechanical, including photocopying, recording, or any information storage and retrieval system, without written permission.



4 Tesseneer Drive
Highland Heights, KY 41076-9753
Phone: 1.800.424.5666
1.859.572.8000
www.generalcable.com

DAT-0001-R0704